

Keysight 8491A/B, 8493A/B/C, 11581A, 11582A and 11583C Coaxial Attenuators

Technical Overview

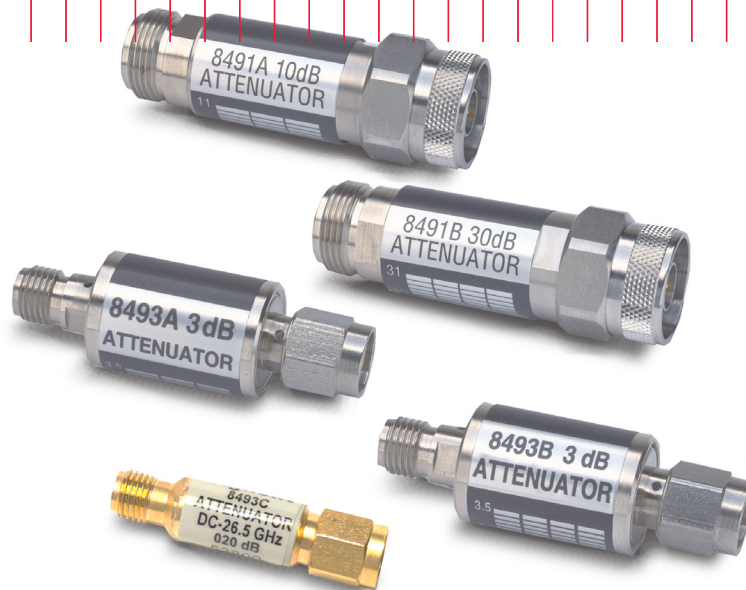

- High accuracy
- Low SWR
- Broadband frequency coverage
- Small size

Description

The Keysight Technologies's coaxial fixed attenuators provide precision attenuation, flat frequency response, and low SWR over broad frequency ranges (dc to 26.5 GHz) at low prices. Attenuators are available in eight attenuation values: 3, 6, 10, 20, 30, 40, 50, and 60 dB; with performances specified from dc to 26.5 GHz; and with choice of four connector types: Type-N, SMA¹, and APC 3.5².

These attenuators are all tested on a state-of-the-art precision analyzer to assure specifications over the full frequency ranges. Although the 8493C is not specified above 26.5 GHz, it performs resonance free to 34 GHz with only a small loss in performance.

Precision construction

The attenuators employ a film on an attenuator card as the resistive element. The uniformity and repeatability of the film deposition process result in high accuracy and low SWR over very wide frequency ranges.

The 8493C features thin-film-tantalumnitride on a sapphire substrate for exceptional precision performance to 26.5 GHz. In fact, it performs resonance-free to 34 GHz, the top frequency limit of the APC-3.5 connector.

The choice of connector type and material also ensure accurate and repeatable attenuation. The 8491A/B attenuators are furnished with Type-N connectors whose dimensions are compatible with either MIL-C-71 or MIL-C-39012 connector specifications.

These connectors are stainless steel for long wear and high repeatability. The 8493A/B attenuators are furnished with SMA type connectors. The connectors are heat treated beryllium copper for greater strength and wear.

The 8493C is furnished with the APC 3.5 connector which is compatible with standard SMA connectors but is more rugged and offers improved repeatability over hundreds of connections.

Quality assurance in testing

The flat frequency response and low SWR of the attenuators are assured over the entire frequency range by full frequency band testing on a state-of-the-art precision analyzer. Full frequency band testing ensures that narrow resonances in the frequency band are not over-looked. Actual attenuation values taken at dc, 4, 8, 12, 18, and 26.5GHz are stamped on the attenuator body for permanent and easy reference.

Testing each attenuator with a state-of-the-art precision analyzer brings standards lab accuracy to production testing because the system can determine its own measurement uncertainties and compensate for them in the testing process. System calibration is derived from precise physical standards which are directly traceable to the National Bureau of Standards. In addition, automatic testing eliminates the possibility of human error in setting instrument controls, taking data, or making calculations.

1. As per USASI Committee C83.2 compatible with OSM, ARM, WPM, BRM, NPM, etc.

2. Mate with MIL-C-71 or MIL-C-39012 connectors.

Applications

Ruggedness, reliability and small size make these attenuators useful both on the bench and in systems applications. With their high accuracy and low SWR they are ideally suited for extending the range of sensitive power meters for higher power measurements and for “padding” poorly matched devices to improve system SWR.

These same characteristics lend themselves to applications as calibration standards in attenuation and RF substitution measurements. With their broad dc to 26.5 GHz frequency range and reasonable cost, general applications, such as the reduction of power level to sensitive components and instrumentation systems, are attractive and appropriate uses for these attenuators.

Accuracy

The accuracy of an attenuator directly affects the accuracy of the measurement where the attenuator is used. In fact, attenuators are used extensively as the standard against which other instruments or devices are calibrated.

Agilent’s fixed attenuators achieve flat frequency response (typically a few hundredths of a dB) and overall accuracy (typically $\pm 2\%$ of value in dB at 26.5 GHz) through the use of thin-film attenuator cards. These cards are composed of high stability tantalum nitride resistive film deposited on a sapphire or alumina substrate.

Quality assurance in specifications

The following examples demonstrate the reliability and comprehensiveness of specifications. Although the absolute accuracy for a 3 dB attenuator is specified as ± 0.3 dB, test data statistics indicate an expected value of $3 \text{ dB} \pm 0.20$ dB from dc to 18 GHz. Similarly a 30 dB attenuator is specified as ± 1.0 dB, but typically is no worse than $30 \text{ dB} \pm 0.75$ dB from dc to 18 GHz. The other attenuation values are also specified as conservatively.

In addition, Keysight precision attenuators meet more comprehensive performance standards. Linear phase response is an example. Not only is wide bandwidth significant, but also linear phase response is an important parameter for applications where pulse distortion must be kept to a minimum. The excellent linearity of the Agilent attenuators is typified in the accompanying illustration of an actual network analyzer measurement.

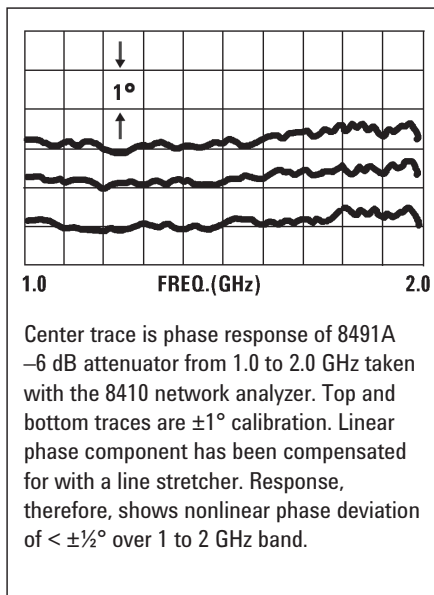

Economy

Automated procedures have resulted in economies of scale in production and testing. The automated resistive film deposition process permits high-volume manufacture with excellent yield. Furthermore, characteristics are consistently uniform; hand “touch-up” is not required to meet specifications. Automatic testing means exceptionally thorough, high-accuracy measurements can be performed in appreciably shorter time than could be done manually.

The overall result is outstanding attenuator performance at attractive prices.

Calibration Data

Optional calibration data

Use of calibration data has always been an effective means of reducing measurement uncertainty at RF and microwave frequencies. This data is available for Keysight’s fixed attenuators as Option 849xx- UK6. Data which is generated by an automatic network analyzer provides a tabulated list of attenuation and SWR’s at 26 to 67 frequencies (see table 2). Measurements to 60 dB are directly traceable to NBS standards and feature very low measurement uncertainties. Option 849xx-UK6 data is available when the attenuators are first purchased and recalibrations are available through Keysight Customer Service Centers around the world.

Table 1. SWR data uncertainties

Connector type	Frequency range (GHz)	Measured SWR	
		1.0 to 1.35	1.35 to 1.86
Male Type -N	dc to 12.4	±0.025	±0.041
	12.4 to 18.0	±0.031	±0.050
Female Type -N	dc to 8.0	±0.025	±0.046
	8.0 to 12.4	±0.031	±0.063
	12.4 to 18.0	±0.042	±0.071
Male SMA	dc to 8.0	±0.031	±0.054
	8.0 to 12.4	±0.045	±0.084
	12.4 to 18.0	±0.077	±0.137
Female SMA	dc to 8.0	±0.054	±0.088
	8.0 to 12.4	±0.077	±0.132
	12.4 to 18.0	±0.122	±0.206
Male APC-3.5	dc to 8.0	±0.025	±0.041
	8.0 to 12.4	±0.031	±0.050
	12.4 to 18.0	±0.045	±0.067
Female APC-3.5	dc to 10	±0.020	±0.031
	10 to 18	±0.025	±0.037
	18 to 26.5	±0.035	±0.050

Table 2. Coaxial attenuator calibration frequencies* (MHz)

100	4500	9000	13000	16750	
500	5000	9500	13500	17000	
1000	5500	10000	14000	17250	
1500	6000	10500	14500	17500	
2000	6500	11000	15000	17750	
2500	7000	11500	15500	18000	
3000	7500	12000	16000	(each 250 MHz	
3500	8000	12400	16250	to 26.5 GHz	
4000	8500	12500	16500		

*dc to 12.4 GHz models include 26 frequencies, dc to 18 GHz models include 42 frequencies, dc to 26.5 GHz models include 67 frequencies (2 to 26.5 GHz).

Table 3. Attenuation data uncertainties

Attenuation (dB)	8491, 8492 and 8493 Attenuation data uncertainty (dB)				
	0.1 to 2.0 GHz	2 to 6 GHz	6 to 12.4 GHz	12.4 to 18.0 GHz	18.0 to 26.5 GHz
3	±0.07	±0.06	±0.07	±0.11	±.15
6	±0.07	±0.07	±0.07	±0.11	±.15
10	±0.08	±0.07	±0.08	±0.12	±.15
20	±0.09	±0.08	±0.09	±0.13	±.15
30	±0.12	±0.11	±0.12	±0.15	±0.18
40	±0.15	±0.14	±0.15	±0.21	±0.25
50	±0.23	±0.23	±0.23	±0.34	n/a
60	±0.50*	±0.48*	±0.90*	±0.90*	n/a

*The uncertainties noted represent 99.7% probability values.

Specifications:

Specifications describe the instruments warranted performance. Supplemental characteristics (shown in italics) are intended to provide information useful in applying the instrument by giving typical, but non-warranted, performance parameters.

Frequency Range:

8491A and 8493A, dc to 12.4 GHz
 8491B, 8493B, dc to 18 GHz
 8493C, dc to 26.5 GHz

Attenuation Accuracy:

	8491A/93A	8491B/93B	8493C
	<i>dc to 12.4 GHz</i>	<i>dc to 12.4 / 12.4 to 18 GHz</i>	<i>dc to 18 / 18 to 26.5 GHz</i>
3 db	±0.3 dB	±0.3 dB	±0.5 dB / ±1.0 dB
6 dB	±0.3 dB	±0.3 dB / ±0.4 dB	±0.6 dB
10 dB	±0.5 dB	±0.6 dB	±0.3 dB / ±0.5 dB
20 dB	±0.5 dB	±0.6 dB / ±1.0 dB	±0.5 dB / ±0.6 dB
30 dB	±1.0 dB	±1.0 dB	±0.7 dB / ±1.0 dB
	8491A only	8491B/92A only	
40 dB	±1.5 dB	±1.5 dB	±1.0 dB / ±1.3 dB
50 dB	±1.5 dB	±1.5 dB	N/A
60 dB	±2.0 dB	±2.0 dB	N/A

SWR:

	8491B/8493B			8493C		
	8491A/8493A					
	<i>dc to 8 (GHz)</i>	<i>8 to 12.4 (GHz)</i>	<i>12.4 to 18 (GHz)</i>	<i>dc to 8</i>	<i>8 to 12.4</i>	<i>12.4 to 26.5</i>
3 db	1.25	1.35	1.5	1.10	1.15	1.25
6 dB	1.2	1.3	1.5	1.10	1.15	1.27
10 dB	1.2	1.3	1.5	1.10	1.15	1.25
20 dB	1.2	1.3	1.5	1.10	1.15	1.25
30 dB	1.2	1.3	1.5	1.10	1.15	1.25
	8491A/B on 8491B only					
40 dB	1.2	1.3	1.5	1.10	1.15	1.25
50 dB	1.2	1.3	1.5	N/A	N/A	N/A
60 dB	1.2	1.3	1.5	N/A	N/A	N/A

Environmental:

Temperature: Operating 0°C to +55°C
Storage -55°C to +85°C
Humidity: Operating <95% relative at 40°C
Storage <95% relative at 40°C
Altitude: Operating <4,600 meters (15,000 feet)
Storage <15,300 meters (50,000 feet)
EMC Radiated interference is within the requirements of MIL STD 461 method RE02, VDE 0871 EN55011 and FCC part 18

		8491 A	8493A	8491B	8493B	8493C	
Connectors (50 Ω)		Type-N2	SMA1	Type-N2	SMA1	APC-3.5	
Dimensions	Millimeters	67 X 21	40 X 13	67 X 21	40 X 13	3,6,10,20 dB	30,40 dB
	Inches	2 7/16 X 13/16 D	1 9/16 X 1/2 D	2 7/16 X 13/16 D	1 9/16 X 1/2 D	33.8 X 8	36.8 X 8
Weight	Net	110 g (4 oz)	30 g (1 oz)	110 g (4 oz)	30 g (1 oz)	8.5 g (0.3 oz)	9.4 g (0.33 oz)
	Shipping	220 g (8 oz)	220 g (8 oz)	220 g (8 oz)	220 g (8 oz)	45 kg (1 lb)	

Supplemental Characteristics:

Temperature stability:
0.0001 dB/dB/°C (all except 8493C)
0.0002 dB/dB/°C (8493C)
Maximum input power: 2 W avg., 100 W peak³
Power sensitivity: 0.001 dB/dB/W (all except 8943) 0.001 dB/W (8493C)

Attenuator Sets

11581A/11582A/11583C

A calibrated set of four fixed coaxial attenuators (3, 6, 10, and 20 dB) is available. Each set includes a calibration report certified traceable to the National Bureau of Standards. The reports included with the 11581A, 11582A, and 11583C indicate the accuracy of measurement and list the attenuation and reflection coefficient at each port of the attenuator.

The set of four attenuators is furnished in a handsome walnut accessory case. In addition to protecting the units when not in use, the case is also a convenient storage place for the attenuators and the calibration reports. Calibration data as described on page 4 is included with rack attenuator set.

Ordering Information

To order, basic model number and option (specifies attenuation value) must be specified. Option 849xx-UK6 calibration data can also be ordered with the basic model number and attenuation value option. Please note, Option 849xx-UK6 is not available with 1158½A nor 11583C.

Attenuation options				
	Atten	8491A/B options	8491A/B options	8491A/B options
Option 003	3 dB	8491x-003	8493x-003	8493C-003
Option 006	6 dB	8491x-006	8493x-006	8493C-006
Option 010	10 dB	8491x-010	8493x-010	8493C-010
Option 020	20 dB	8491x-020	8493x-020	8493C-020
Option 030	30 dB	8491x-030	8493x-030	8493C-030
Option 040	40 dB	8491x-040		8493C-040
Option 050	50 dB	8491x-050		
Option 060	60 dB	8491x-060		

Note: x = A or B

1. As per USASI Committee C83.2 compatible with OSM, ARM, WPM, BRM, NPM, etc.
2. Mate with MIL-C-71 or MIL-C-39012 connectors
3. At 20°C derated to 1.3 W avg. at 55°C.

8491A/B

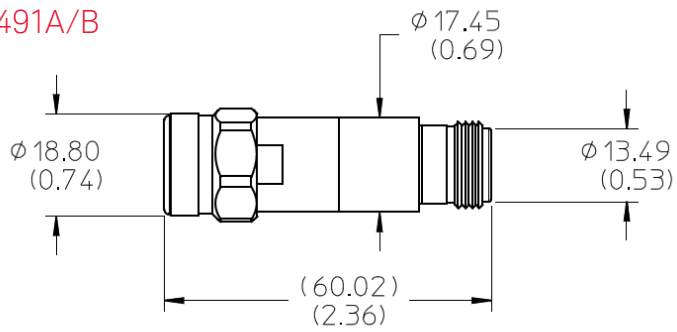

8493A/B

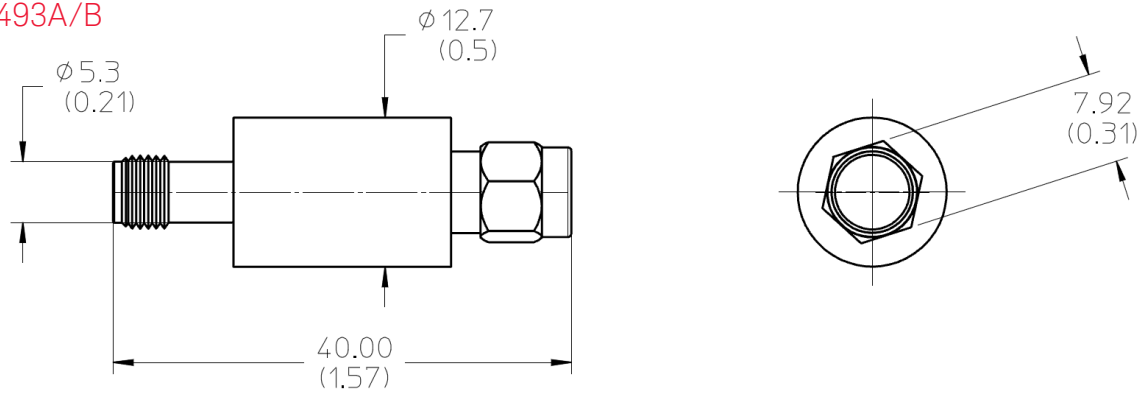

8493C

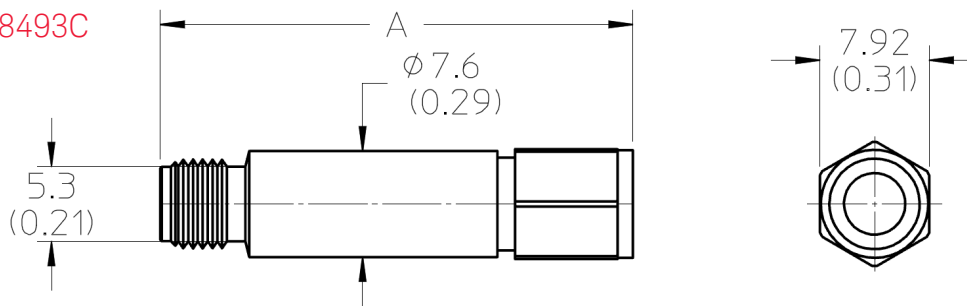

myKeysight

myKeysight

www.keysight.com/find/mykeysight

A personalized view into the information most relevant to you.



www.axiestandard.org

AdvancedTCA® Extensions for Instrumentation and Test (AXIe) is an open standard that extends the AdvancedTCA for general purpose and semiconductor test. Keysight is a founding member of the AXIe consortium.



www.lxistandard.org

LAN eXtensions for Instruments puts the power of Ethernet and the Web inside your test systems. Keysight is a founding member of the LXI consortium.



www.pxisa.org

PCI eXtensions for Instrumentation (PXI) modular instrumentation delivers a rugged, PC-based high-performance measurement and automation system.



www.keysight.com/quality

Keysight Electronic Measurement Group

DEKRA Certified ISO 9001:2008

Quality Management System

Keysight Channel Partners

www.keysight.com/find/channelpartners

Get the best of both worlds: Keysight's measurement expertise and product breadth, combined with channel partner convenience.

ATCA®, AdvancedTCA®, and the ATCA logo are registered US trademarks of the PCI Industrial Computer Manufacturers Group.

www.keysight.com/find/mta

For more information on Keysight Technologies' products, applications or services, please contact your local Keysight office. The complete list is available at: www.keysight.com/find/contactus

Americas

Canada	(877) 894 4414
Brazil	55 11 3351 7010
Mexico	001 800 254 2440
United States	(800) 829 4444

Asia Pacific

Australia	1 800 629 485
China	800 810 0189
Hong Kong	800 938 693
India	1 800 112 929
Japan	0120 (421) 345
Korea	080 769 0800
Malaysia	1 800 888 848
Singapore	1 800 375 8100
Taiwan	0800 047 866
Other AP Countries	(65) 6375 8100

Europe & Middle East

Austria	0800 001122
Belgium	0800 58580
Finland	0800 523252
France	0805 980333
Germany	0800 6270999
Ireland	1800 832700
Israel	1 809 343051
Italy	800 599100
Luxembourg	+32 800 58580
Netherlands	0800 0233200
Russia	8800 5009286
Spain	0800 000154
Sweden	0200 882255
Switzerland	0800 805353
	Opt. 1 (DE)
	Opt. 2 (FR)
	Opt. 3 (IT)
United Kingdom	0800 0260637

For other unlisted countries:
www.keysight.com/find/contactus
 (BP-06-09-14)