

R&S®SFE

Broadcast Tester

The compact solution
for all major TV and
broadcasting standards



R&S®SFE

Broadcast Tester

At a glance

The R&S®SFE is a multistandard signal generator that supports all common TV standards and a number of audio broadcasting standards. Whether analog or digital terrestrial TV, cable, satellite or mobile TV, or sound broadcasting – the R&S®SFE modulates all these signals in realtime, combining a high-quality RF modulator, a universal realtime coder and diverse baseband signal sources in a single unit.

The R&S®SFE's modular design allows users to tailor the instrument to their own requirements – for example by adding an integrated noise generator or a BER tester. Moreover, the R&S®SFE is the first instrument in its class to feature a powerful integrated fading simulator. Even after purchase, the R&S®SFE can be quickly and easily upgraded to cover new modulation modes by enabling pre-installed software options.

The instrument's versatile baseband signal sources for digital TV standards make it possible to replay test signals from Rohde&Schwarz libraries as well as proprietary transport streams. For analog TV, the R&S®SFE can be installed with an integrated audio/video test signal generator. Alternatively, the instrument can be fed with transport streams or analog A/V signals from external generators. An optional arbitrary (ARB) waveform generator allows the user to create any type of modulation signal regardless of the realtime coders installed. The R&S®SFE is compact and requires only little space. It offers the same convenient graphical user interface as the high-end R&S®SFU broadcast test system, plus full remote control capability.

The R&S®SFE's multistandard capability and flexible customization options make it an extremely versatile instrument for many lab applications. Moreover, with its excellent price/performance ratio, it is also a valuable tool in service and quality assurance. And, last but not least, featuring short switching times, an optional ARB waveform generator and a highly compact design, the R&S®SFE is a cost-efficient solution for production applications.

Key facts

- Multistandard signal generator
- Frequency range up to 2700 MHz
- High-precision modulator (MER typ. 43 dB)
- Integrated 12 path fading simulator
- Integrated noise source, BER tester and transport stream generator



Front view of the R&S®SFE.

R&S®SFE

Broadcast Tester

Benefits and key features

Versatile multistandard signal generator with realtime coding

- ▮ Digital and analog TV standards for cable, satellite and terrestrial transmission
- ▮ Digital and analog audio broadcasting standards
- ▮ Realtime signal generation with selectable modulation and coding parameters
- ▮ Standards available as software options

▷ [page 4](#)

High-precision signal generation over wide frequency and level range

- ▮ Frequency range 100 kHz to 2700 MHz
- ▮ Level range -110 dBm to +15 dBm
- ▮ Extremely short switching times
- ▮ Low phase noise and high MER

▷ [page 6](#)

Integrated transport stream generator and audio/video generator

- ▮ Generation and replay of endless and seamless transport streams
- ▮ Comprehensive transport stream libraries from Rohde&Schwarz
- ▮ Audio/video generator with test pattern library for analog TV
- ▮ Customized test signals

▷ [page 7](#)

Flexible signal generation with ARB waveform generator

- ▮ Large ARB memory and high sample rates
- ▮ Waveform libraries from Rohde&Schwarz
- ▮ Compatible with R&S®WinIQSIMTM
- ▮ Digital I/Q input

▷ [page 9](#)

Simulation of multipath propagation and single-frequency networks

- ▮ Integrated fading simulator
- ▮ Predefined scenarios
- ▮ Fading profiles

▷ [page 10](#)

Receiver tests with noise source and BER tester

- ▮ Integrated broadband AWGN generator
- ▮ BER measurement at transport stream or bit level

▷ [page 12](#)

Compact design and convenient graphical user interface

- ▮ ½ 19" x 3 HU cabinet with large VGA color display
- ▮ Intuitive user interface under Windows XP Embedded
- ▮ Context-sensitive help system
- ▮ User-definable favorites for quick access
- ▮ Remote control and remote operation via LAN

▷ [page 13](#)

Versatile multistandard signal generator with realtime coding

The R&S®SFE broadcast tester is a multistandard instrument that supports all common broadcast systems. Whether audio or TV, analog or digital, terrestrial, satellite or cable – the R&S®SFE covers all these standards in a single unit. Switching between different standards is quick and easy – at the press of a key. Additional and future standards can be added at any time with a software update.

Digital and analog TV standards for cable, satellite and terrestrial transmission

The R&S®SFE supports the following TV standards:

- ▮ Digital terrestrial TV: DVB-T2, DVB-T, ATSC/8VSB, ISDB-T, ISDB-T_B, DTMB
- ▮ Digital satellite TV: DVB-S, DVB-S2, DirecTV
- ▮ Digital cable TV: DVB-C, J.83/B, ISDB-C
- ▮ Digital mobile TV: DVB-H, T-DMB, ISDB-T 1 Segment, CMMB, MediaFLO™, ATSC M/H
- ▮ Analog TV: B/G, D/K, M/N, I, L standards

Digital and analog audio broadcasting standards

The R&S®SFE supports the following audio broadcasting standards:

- ▮ Digital audio broadcasting: DAB, DAB+, ISDB-T_{SB}, HD Radio™¹⁾, DRM¹⁾, DRM+^{1), 2)}
- ▮ Analog audio broadcasting: FM stereo with RDS, FM mono, AM

¹⁾ Provided as ARB waveform library

²⁾ Currently in preparation.

Overview of broadcasting systems in use worldwide.

Transmission	Standard	Europe	North America	South America	Asia	Australia	Africa
Terrestrial TV	DVB-T2	•					
	DVB-T	•			•	•	•
	ATSC/8VSB		•				
	ISDB-T			•	•		
	DTMB				•		
	Analog	•	•	•	•	•	•
Cable TV	DVB-C	•					
	J.83B		•				
	ISDB-C				•		
Satellite TV	DVB-S	•			•		
	DVB-S2	•	•		•		
	DirecTV		•	•			
Mobile TV	DVB-H	•				•	•
	T-DMB	•			•		
	ISDB-T 1 seg			•	•		
	CMMB				•		
	MediaFLO™		•				
	ATSC-M/H		•				
Audio broadcasting	DAB	•				•	
	DRM	•					
	ISDB-T _{SB}			•	•		
	AM/FM	•	•	•	•	•	•

Realtime signal generation with selectable modulation and coding parameters

The key functionality of the R&S®SFE broadcast tester is to generate modulated signals for various transmission standards in realtime. The R&S®SFE achieves this by means of a powerful universal hardware platform for baseband signal processing. This platform provides the I and Q bit streams for the broadband vector modulator. A highly accurate spectrum is thus obtained for all modulation modes. The required transmission standard is made available simply by loading the appropriate FPGA firmware. For each transmission standard, various modulation parameters such as constellation, code rate and FFT mode have to be defined. These parameters can be varied regardless of the transport stream to be transmitted (as far as the standard allows this; in the case of MediaFLO™, for example, the transport stream contains control information for setting the coding parameters in the modulator). It is thus possible to test all the conceivable configurations of a standard. The realtime coder automatically adapts the signaling information as required for the receiver.

Standards available as software options

All modulation modes for the realtime coder of the R&S®SFE are implemented as firmware, making it quick and easy to add transmission standards. The standards are pre-installed and can be enabled by entering a key code.

Signals for terrestrial, satellite and analog TV.

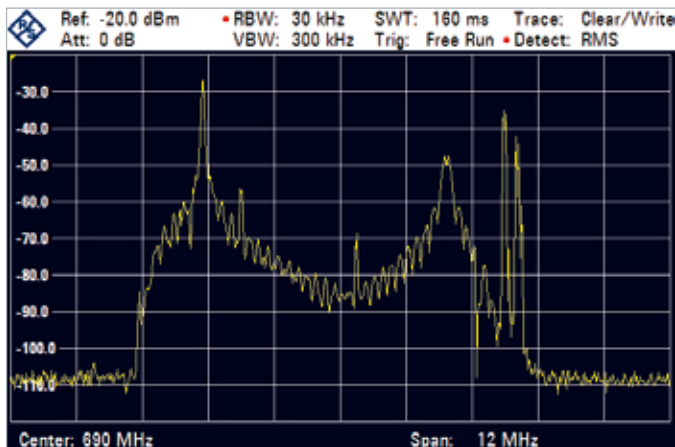
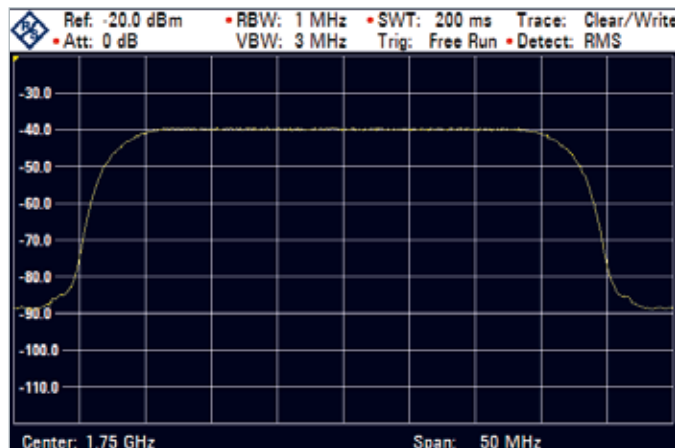
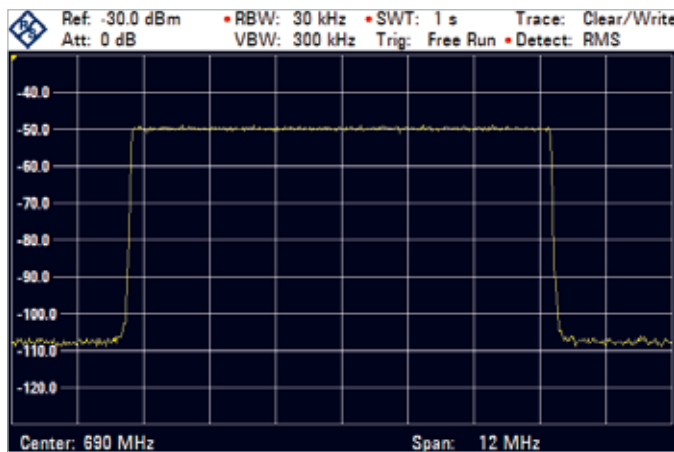

High-precision signal generation over wide frequency and level range

From the IF, the VHF, UHF and the L band all the way up to the S band – the R&S®SFE broadcast tester covers the entire frequency range for broadcasting applications. And it does so offering exceptional signal quality for an instrument in this class.

Frequency range 100 kHz to 2700 MHz

The frequency can be set in steps of 1 Hz. Either the channel center frequency or the vision carrier frequency or a channel number from the selected channel table can be entered.

Level range –110 dBm to +15 dBm

The output level of the R&S®SFE is adjustable in steps of 0.1 dB over a wide dynamic range from –110 dBm to +15 dBm. It is thus possible to test tuners through their full drive range, from the sensitivity threshold up to saturation. The instrument's wear-free electronic attenuator enables a virtually unlimited number of switching cycles with excellent reproducibility.

Extremely short switching times

Short test times boost efficiency and reduce costs in the production of consumer electronics. Featuring extremely short switching times, the R&S®SFE significantly contributes toward minimizing test times. Level, frequency and parameter switching is accomplished in less than 20 milliseconds, and even switching between modulation standards takes no more than approx. six seconds.

Low phase noise and high MER

Advanced COFDM modulation methods place high demands on the stability and spectral purity of the oscillator signal. With an SSB phase noise of typ. < –115 dBc (at 300 MHz and 20 kHz carrier offset), the R&S®SFE offers very high MER values of typically up to 43 dB. Moreover, the R&S®SFE stands out for its low broadband noise and high harmonics suppression.

Constellation diagram of an ISDB T signal with excellent MER.

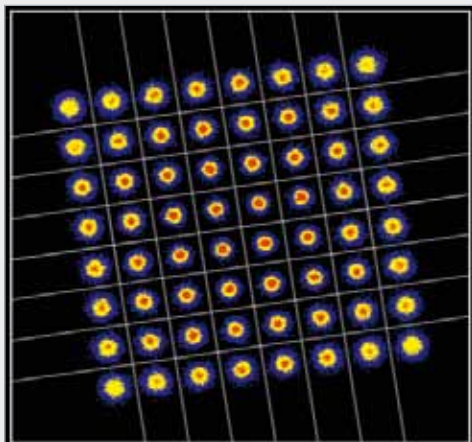

Gedrehte DVB-T2-Konstellation mit weißem Rauschen.

DVB T2: Next-generation digital terrestrial TV

DVB T2 is the new European standard for digital terrestrial TV. It enables data rates unattained so far, and thus for the first time allows the efficient transmission of HDTV programs over terrestrial channels. Using 16k and 32k FFT modes, 256QAM and rotated constellations, the new standard places exacting demands in terms of signal generation. The R&S®SFE's powerful FPGA-based realtime coder supports all modulation and coding parameters in line with the DVB-T2 standard. ¹⁾

¹⁾ For single physical layer pipe (PLP). Multi-PLP support in preparation.

Integrated transport stream generator and audio/video-generator

Digital transmission methods require transport streams as baseband signals, whereas modulators for analog TV require CCVS signals. Both of these are fed to the R&S®SFE via inputs on the rear panel. Alternatively, baseband sources appropriate for the enabled transmission standards can be installed in the R&S®SFE – eliminating the need for external transport stream or test pattern generators. This significantly reduces the number of instruments required.

Generation and replay of endless and seamless transport streams

The optional internal transport stream generator supplies test streams in the baseband for the realtime coder. It can be used to generate endless and seamless high-bit-rate MPEG-2 transport streams. The transport stream generator comes with a comprehensive SDTV¹⁾ transport stream library.

The optional transport stream player ideally complements the transport stream generator and allows customers to replay their own transport streams in TRP format. The transport stream player is also used to replay DAB, DAB+ and T-DMB ETI streams as well as MediaFLO™ and CM-MB streams. Moreover, it replays MPEG 2 transport streams endlessly and seamlessly. In the process, it continuously updates the PCR, DTS, PTS time stamps and continuity counter information, and overwrites the TDT and TOT time information with the R&S®SFE system time²⁾.

The R&S®SFE-K22 integrated transport stream player.

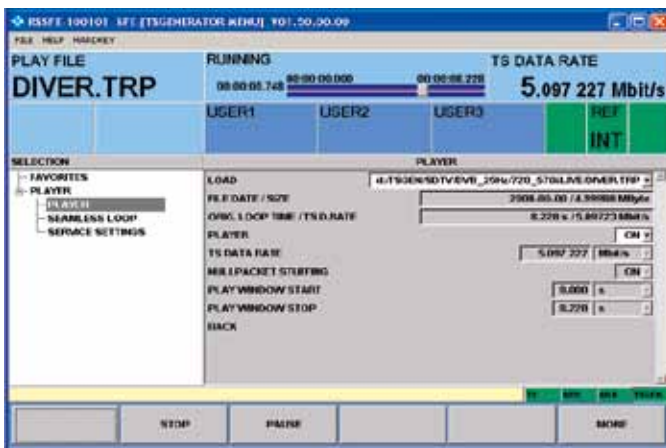

¹⁾ Standard definition television.

²⁾ PCR: program clock reference, DTS: decoding time stamp, PTS: presentation time stamp, TDT: time and date table, TOT: time offset table.

The transport stream player continuously updates the information in the blue fields.

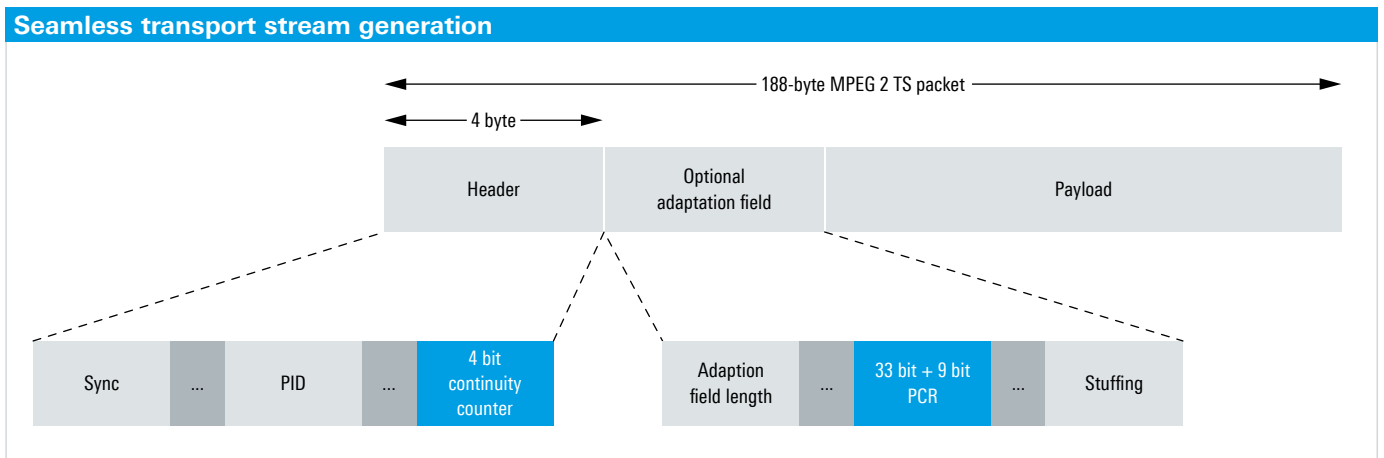

Comprehensive transport stream libraries from Rohde & Schwarz

Rohde & Schwarz offers a large number of transport stream libraries for its broadcast signal generators ¹⁾. For the transport stream generator, libraries for SDTV, HDTV, H.264, DVB-H, ISDB-T and TCM are available. The transport stream player supports libraries for DAB, DAB+, CMMB, ATSC-M/H, ISDB-TB and MediaFLO™.

Audio/video generator with test pattern library for analog TV

The audio/video generator delivers test patterns and audio signals for analog TV. It comes with a set of FuBK and color bar test patterns for PAL, SECAM and NTSC. In addition, an ATV video library is available from Rohde & Schwarz that provides a broad range of test patterns for analog TV that far exceeds the basic set of test patterns supplied with the audio/video generator.

Customized test signals

Rohde & Schwarz provides customized MPEG 2 transport streams and analog CCVS signals as a service. The signal content is customer-defined. Still images or video sequences can be used as video content. Customized transport streams may include system information for DVB, ATSC, ISDB and DTMB, as well as audio signals or audio sequences. Since the CCVS signals carry no audio content, the audio signal is delivered directly by the R&S®SFE audio generator.

Test signals from different Rohde & Schwarz test signal libraries.

Test signal: "Color bars".



Test signal: "HDTV test pattern".

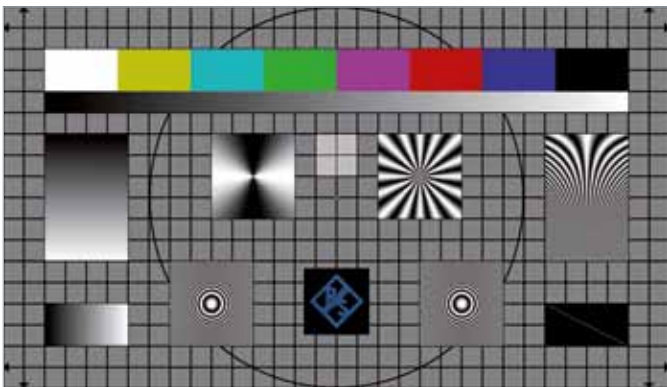

Live sequence: "Flowers".



¹⁾ See data sheet "Stream Libraries for broadcasting T&M equipment from Rohde & Schwarz", PD 5213.7202.32.

Flexible signal generation with ARB waveform generator

Signal generation for HD Radio™ with the R&S®SFE-K35 ARB waveform generator.

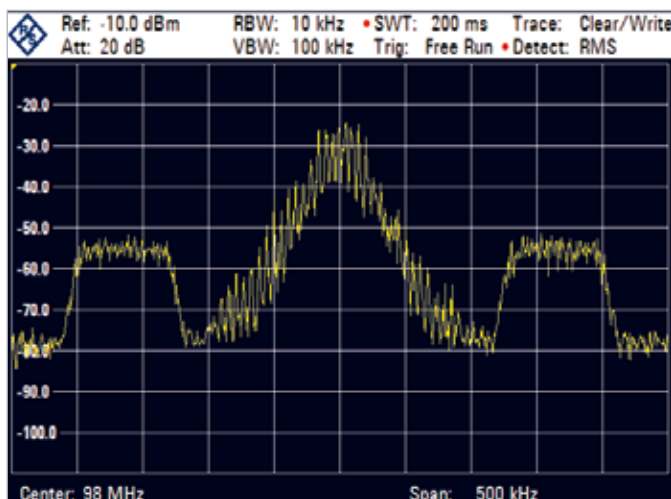

The optional integrated arbitrary waveform (ARB) generator of the R&S®SFE can replay proprietary I/Q waveforms as well as waveforms from Rohde & Schwarz libraries. It is thus possible to generate any externally computed RF signal. Modulation signals are generated regardless of the realtime coders installed.

Large ARB memory and high sample rates

Offering 256 Msample memory space and sample rates up to 100 Msample/s, the ARB generator of the R&S®SFE is among the most powerful generators in its class. For example, it can supply signals together with multiple adjacent analog or digital TV channels as needed to simulate cable TV networks.

Waveform libraries from Rohde & Schwarz

Rohde & Schwarz offers ARB waveform libraries for the following broadcasting standards: HD Radio™, DRM, DRM+²⁾, DVB-T2, MediaFLO™ and T-DMB/DAB. The range of available waveform libraries is continuously being expanded.

Compatible with R&S®WinIQSIM™

The R&S®SFE supports the use of the R&S®WinIQSIM™ simulation software. Waveforms generated with R&S®WinIQSIM™ can be loaded into the ARB waveform generator of the R&S®SFE and replayed.

Digital I/Q input

Via the optional digital I/Q interface, I/Q signals from other Rohde & Schwarz instruments can be applied directly to the R&S®SFE modulator. This makes it possible, for example, to expand an R&S®SFU broadcast test system into a dual-channel TV signal generator capable of testing receivers operating in antenna diversity mode.

²⁾ Currently in preparation.

Block diagram of the R&S®SFE with baseband signal sources, fading simulator and noise generator

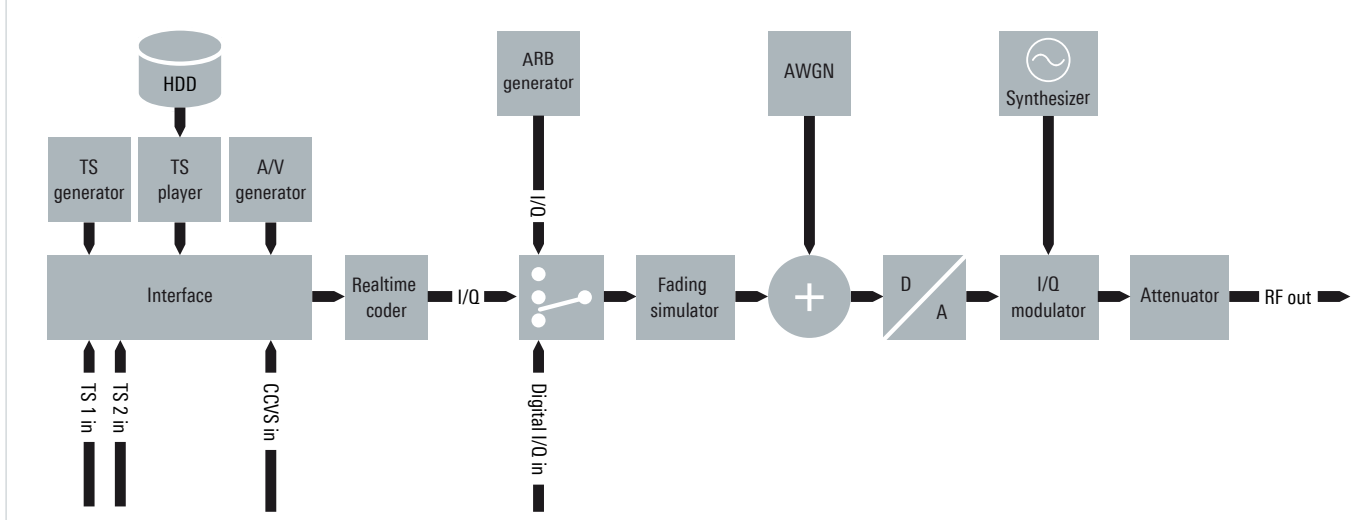

Simulation of multipath propagation and single-frequency networks

The fading simulator opens up new applications for the R&S®SFE in the development and certification of TV receivers. It provides reproducible simulations of multipath and mobile reception. It also simulates specific reception conditions encountered in single-frequency networks (SFNs), such as pre-echoes and echoes outside the guard interval.

Integrated fading simulator

The fading simulator is a software option which requires the R&S®SFE hardware to be expanded with a powerful FPGA. It can simulate up to 12 paths, which are divided into two groups of six paths. The path loss, delay, fading profile and Doppler shift can be defined individually for each path. The paths within a group can be delayed by up to 40 microseconds relative to one another. A maximum additional delay of 5.242 milliseconds can be introduced between the first group and the second group.

Predefined scenarios

Some standardization organizations such as DVB, ATTC and MediaFLO™ stipulate defined fading scenarios for compliance tests. The R&S®SFE fading simulator comes with a large number of predefined scenarios (channel models), including familiar ones such as Typical Urban (TU6), Rural Area (RA6), ATTC Static Multipath and Brazil A to D.

Control of the fading simulator via the R&S®SFE's graphical user interface.

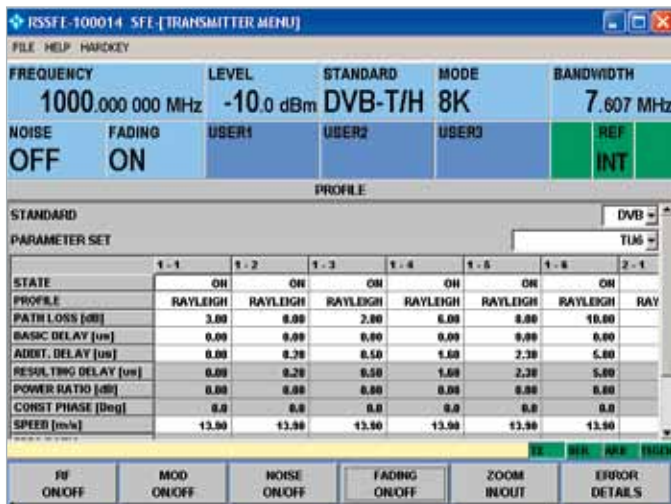

Block diagram of fading simulator with 12 paths divided into two groups

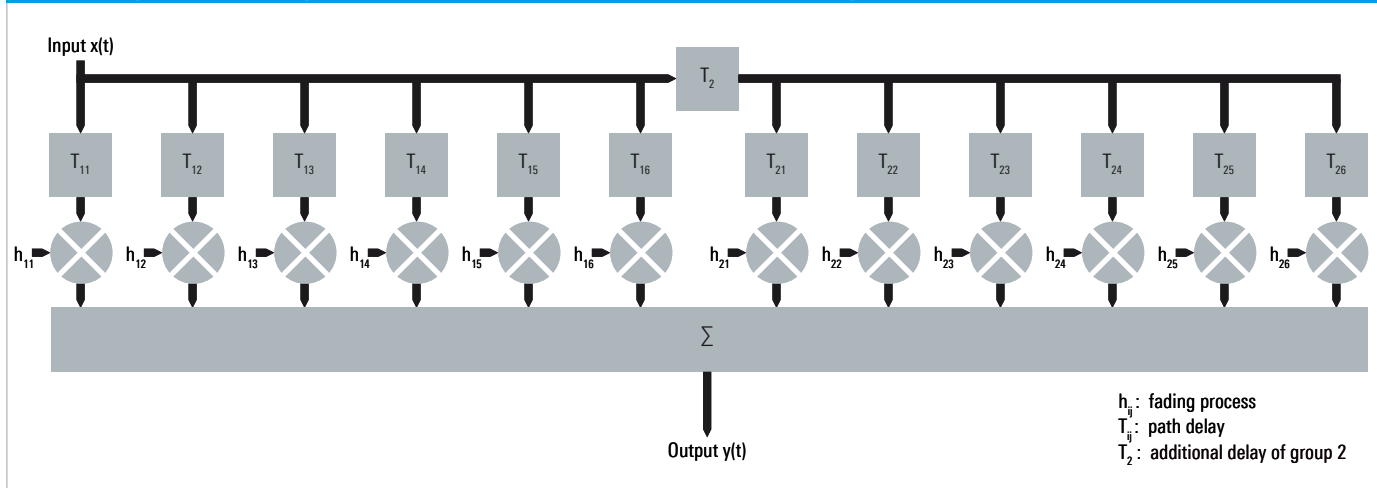

Fading profiles

The fading simulator of the R&S®SFE supports various fading profiles to simulate different propagation conditions. The profiles can be combined as required.

- **Static Path**
is the simplest channel model. It simulates a static transmission path with definable path loss and delay
- **Constant Phase**
also simulates a static transmission path. Here, the signal experiences a definable, constant phase shift as caused, for example, by reflection from metal objects
- **Pure Doppler**
simulates a single transmission path from a transmitter to a moving receiver. The frequency of the received signal varies proportionally to the speed of movement
- **Rayleigh (also known as Classical)**
simulates signal propagation in densely built-up urban areas, i.e. radio traffic areas where many different partial signals arrive at a moving receiver. The signals are produced by reflection, refraction, scattering and diffraction of the original signal. The resulting field strength at the receiver varies as a function of time. Its probability density function exhibits a Rayleigh distribution.
- **Rice**

is a combination of a Rayleigh and a Pure Doppler profile. Many strongly scattered partial signals arrive at a moving receiver. There is a direct line of sight (LOS) between the receiver and the transmitter. The probability density function of the received field strength exhibits a Rician distribution.

Channel impulse response with 12 fading paths divided in two groups.

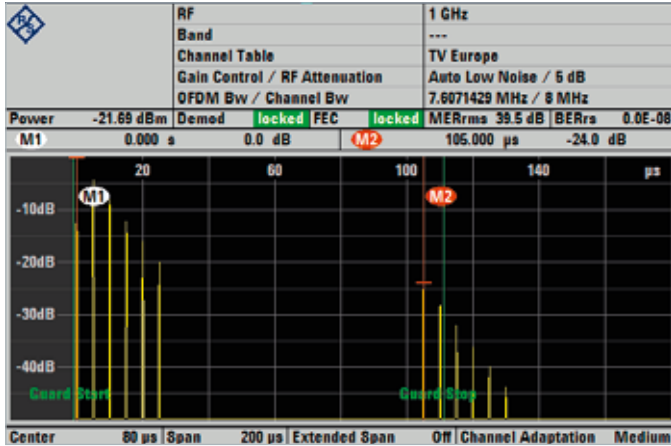

DVB T spectrum exhibiting two deep dips caused by fading.

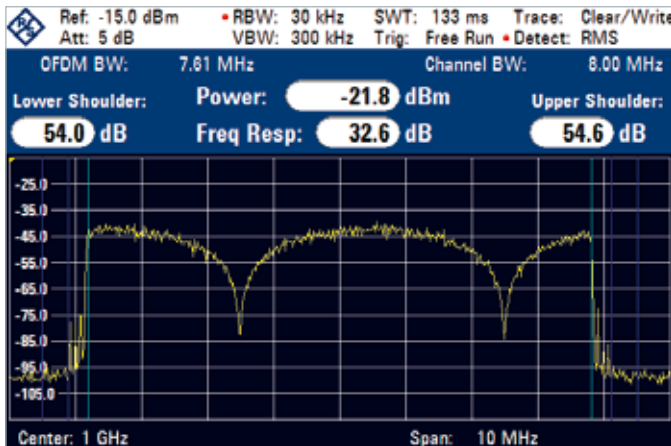

Typical DVB T spectrum distortion obtained with the TU6 channel model.

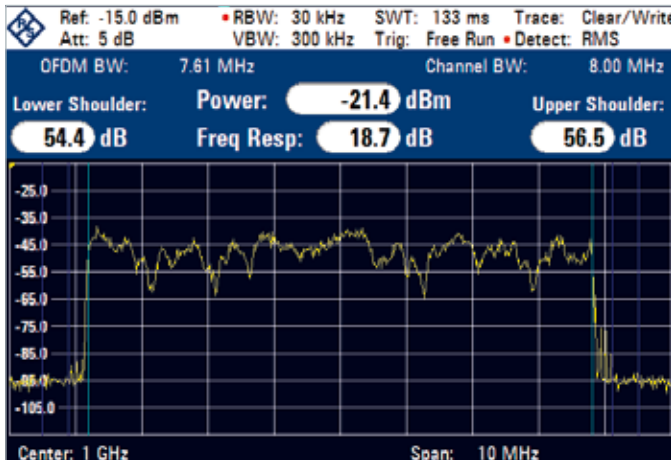

Receiver tests with noise source and BER tester

Integrated broadband AWGN generator

The optional noise generator produces additive white Gaussian noise (AWGN) in the R&S®SFE's digital baseband signal processing section. The AWGN signal is either superimposed on the useful signal or output as a pure noise signal. The signal-to-noise ratio (SNR) can be adjusted over a wide range. The noise generator option supplies broadband white noise with a 3 dB bandwidth of 96 MHz.

BER measurement at transport stream or bit level

Many test specifications define a specific bit error ratio (BER) as an objective criterion for assessing reception quality. For example, the IEC 62002 (MBRAI) standard specifies a BER not exceeding 2×10^{-4} after the Viterbi decoder for DVB-T transmissions. The R&S®SFE's BER measurement option makes it easy to verify compliance with specified limit values. To measure the BER, the instrument's realtime coder generates a signal carrying a pseudo-random binary sequence (PRBS) as a payload. The device under test (DUT) decodes the PRBS signal and feeds it back to the R&S®SFE either as a bit sequence with the associated clock or as an MPEG 2 transport stream. The BER measurement option compares the sent and the received PRBS and displays the BER. The user can define the measurement duration. For long-term measurements, the BER measurement option generates a log file.

DVB T signal with and without superimposed broadband white noise.

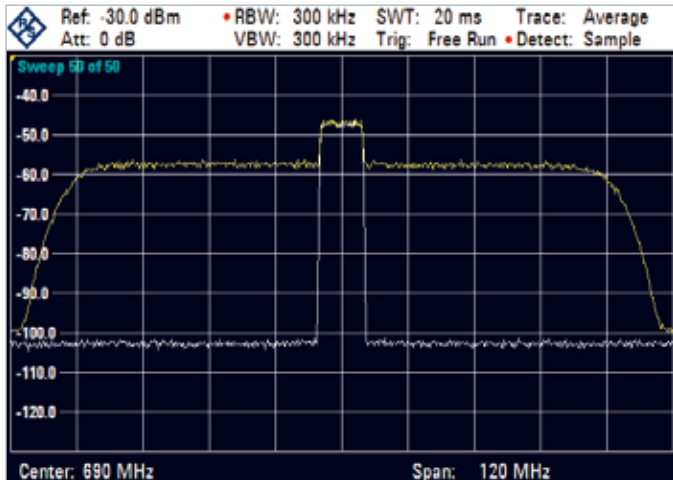

The integrated noise generator and BER tester are valuable tools in receiver development.



Principle of BER measurement

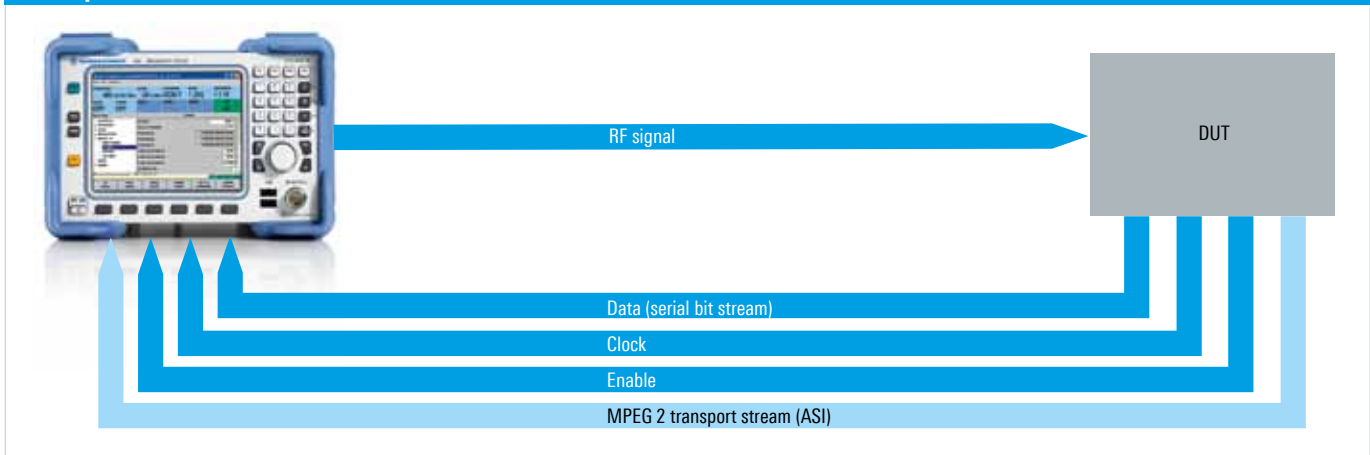

Compact design and convenient graphical user interface

Compact design need not be at the expense of operating convenience. While the R&S®SFE broadcast tester is only half as wide as the R&S®SFU broadcast test system, it supports the same extensive range of control functions – for both local and remote operation.

½ 19" x 3 HU cabinet with large VGA color display

The R&S®SFE is a highly compact instrument, featuring a cabinet only ½ 19" in width. This is a particular asset in production environments, where many instruments have to be installed in racks in a limited space. Despite its small size, the R&S®SFE has an easy-to-read 5.7" VGA color display which, together with the straightforward graphical user interface (GUI), enables simple and reliable operation of the instrument. The main operating parameters are visible at a glance.

Intuitive user interface under WindowsXP Embedded

The R&S®SFE's GUI is already a success on the R&S®SFU broadcast test system. It is straightforward, with a tree on the left side and a work view on the right side. The instrument is operated via a keypad and a rotary knob. Additionally, a keyboard and a mouse can be connected via the USB interfaces.

Context-sensitive help system.

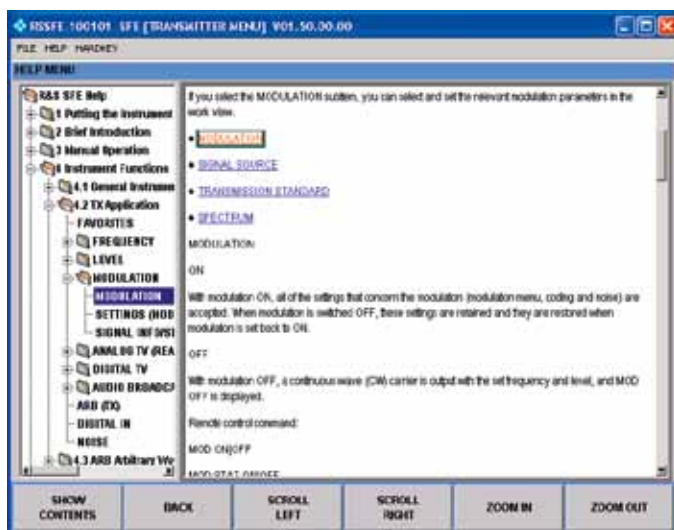

Context-sensitive help system

The R&S®SFE's extensive help system includes all the information contained in the operating manual. It can be accessed during operation. The help system is context-sensitive, i.e. it provides information on the currently selected operating parameter.

User-definable favorites for quick access

Frequently-used parameters can be added to the favorites menu. This function makes operation even quicker and easier. It is especially helpful if parameters from different submenus need to be changed frequently.

Remote control and remote operation via LAN

The R&S®SFE can be remotely controlled via an Ethernet connection or in a LAN over IP. It is preconfigured for the use of DHCP. Remote operation is very easy with the Windows Remote Desktop software or the additional VNC software supplied with the instrument.

Remote control is by means of SCPI commands via LAN (VXI11). The R&S®SFE can thus be easily integrated into existing test programs. Remote control commands are compatible with those used for the R&S®SFU and R&S®SFE100. Rohde&Schwarz also provides drivers for LabWindows/CVI, LabView and VXIplug & play.

Large display with straightforward graphical user interface.



Large display with straightforward graphical user interface.

Specifications in brief

Specifications		
RF signal		
Frequency range		100 kHz to 2.7 GHz
Frequency resolution		1 Hz
Level		-110 dBm to +15 dBm
Level accuracy		< 1.0 dB
Spectral purity		
SSB phase noise	at 300 MHz and 20 kHz carrier offset	< -115 dBc (1 Hz)
Broadband noise	> 10 MHz	< -135 dBc (1 Hz)
Digitale Echtzeit-Modulationssysteme		
Terrestrial TV		DVB-T2, DVB-T, DTMB, ISDB-T, ISDB-T _B , ASTC/8VSB
Cable TV		DVB-C, J.83/B, ISDB-C
Satellite TV		DVB-S, DVB-S2, DirecTV
Mobile TV		DVB-H, T-DMB, ISDB-T 1 seg., MediaFLO™, CMMB, ATSC-M/H
Digital audio broadcasting		DAB, DAB+, ISDB-T _{SB}
Analog realtime modulation systems		
Analog TV		B/G, D/K, I, M/N, L
Analog audio broadcasting		AM, FM mono, FM stereo with RDS
ARB-based modulation systems		
Digital audio broadcasting		HD Radio™, DRM, DRM+ ¹⁾
Digital TV		DVB-T2, CMMB, MediaFLO™
Baseband signal sources		
Transport stream generator	file format	GTS, Rohde & Schwarz proprietary
	data rate (including null packets)	100 kbit/s to 214 Mbit/s
Transport stream player	file format	TRP, T10, ETI, FLO, MFS, PMS, BIN
	data rate	100 kbit/s to 90 Mbit/s
ARB waveform generator	memory	256 Msample
	sample rate	up to 100 Msample/s
Simulation and analysis functions		
AWGN generator	signal-to-noise ratio (SNR)	-30 dB to +60 dB
Fading simulator	number of paths	12
	fading profiles	Static, Constant Phase, Pure Doppler, Rayleigh, Rice
BER measurement	PRBS measurement	clock, data, enable inputs
	MPEG 2 transport stream measurement	ASI input
General data		
Operating temperature range		+5 °C to +45 °C
Power supply		90 V to 240 V AC, 50 Hz to 60 Hz
Dimensions		235 mm × 155 mm × 465 mm
Weight		6 kg

¹⁾ Currently in preparation.

Ordering information

Designation	Type	Order No.
Broadcast Tester	R&S®SFE	2112.4300.02
Options		
Digital modulation systems		
DVB-T/H Coder	R&S®SFE-K1	2113.4010.02
DVB-T2 Coder	R&S®SFE-K16	2113.4290.02
ISDB-T/ISDB-T _{SB} /ISDB-T _B Coder	R&S®SFE-K6	2113.4110.02
DTMB Coder	R&S®SFE-K12	2113.4210.02
ATSC/8VSB Coder	R&S®SFE-K4	2113.4078.02
ATSC-M/H Coder	R&S®SFE-K18	2113.4332.02
MediaFLO™ Coder	R&S®SFE-K10	2113.4178.02
T-DMB/DAB Coder	R&S®SFE-K11	2113.4190.02
CMMB Coder	R&S®SFE-K15	2113.4278.02
DVB-C/ISDB-C Coder	R&S®SFE-K2	2113.4032.02
J.83/B Coder	R&S®SFE-K5	2113.4090.02
DVB-S/DVB-DSNG Coder	R&S®SFE-K3	2113.4055.02
DVB-S2 Coder	R&S®SFE-K8	2113.4132.02
DirecTV Legacy Modulation Coder	R&S®SFE-K9	2113.4155.02
Analog modulation systems		
AM/FM/RDS Coder	R&S®SFE-K170	2113.4423.02
ATV Standard B/G Coder	R&S®SFE-K190	2113.4655.02
ATV Standard D/K Coder	R&S®SFE-K191	2113.4678.02
ATV Standard I Coder	R&S®SFE-K192	2113.4690.02
ATV Standard M/N Coder	R&S®SFE-K193	2113.4710.02
ATV Standard L Coder	R&S®SFE-K194	2113.4732.02
ATV Multistandard Coder	R&S®SFE-K195	2113.4755.02
ARB waveform generator		
ARB Waveform Generator	R&S®SFE-K35	2113.4932.02
ARB Memory Expansion	R&S®SFE-B3	2112.4500.02
R&S®WinIQSIM™ Simulation Software	R&S®SFE-K350	2113.4955.02
Digital baseband		
TS Generator including SDTV transport stream libraries	R&S®SFE-K20	2113.4878.02
TRP Player	R&S®SFE-K22	2113.5274.02
TS Generator/Player	R&S®SFE-PK20	2113.6035.02
Analog baseband		
Video Generator	R&S®SFE-K23	2113.4890.02
Simulation, analysis and other options		
Fading Simulator	R&S®SFE-K30	2113.5074.02
AWGN Generator	R&S®SFE-K40	2113.4910.02
BER Measurement	R&S®SFE-K60	2113.5151.02
Digital I/Q Input	R&S®SFE-K80	2113.5251.02
Additional Hard Disk (CompactFlash)	R&S®SFE-B6	2112.4522.02
Coder Extension Board 15	R&S®SFE-B15	2112.4200.02

For data sheet see PD 5213.8596.22 and www.rohde-schwarz.com.

Your local Rohde&Schwarz expert will help you determine the optimum solution for your requirements.

To find your nearest Rohde&Schwarz representative, visit

www.sales.rohde-schwarz.com

Service you can rely on

- ▮ Worldwide
- ▮ Local and personalized
- ▮ Customized and flexible
- ▮ Uncompromising quality
- ▮ Long-term dependability

About Rohde & Schwarz

Rohde & Schwarz is an independent group of companies specializing in electronics. It is a leading supplier of solutions in the fields of test and measurement, broadcasting, radiomonitoring and radiolocation, as well as secure communications. Established more than 75 years ago, Rohde & Schwarz has a global presence and a dedicated service network in over 70 countries. Company headquarters are in Munich, Germany.

Environmental commitment

- ▮ Energy-efficient products
- ▮ Continuous improvement in environmental sustainability
- ▮ ISO 14001-certified environmental management system

Certified Quality System
ISO 9001

Rohde & Schwarz GmbH & Co. KG

www.rohde-schwarz.com

Regional contact

- ▮ Europe, Africa, Middle East
+49 89 4129 137 74
customersupport@rohde-schwarz.com
- ▮ North America
1 888 TEST RSA (1 888 837 87 72)
customer.support@rsa.rohde-schwarz.com
- ▮ Latin America
+1 410 910 79 88
customersupport.la@rohde-schwarz.com
- ▮ Asia/Pacific
+65 65 13 04 88
customersupport.asia@rohde-schwarz.com