

Keysight Technologies

33330B/C Coaxial Detectors for OEM and Systems Use

Technical Overview

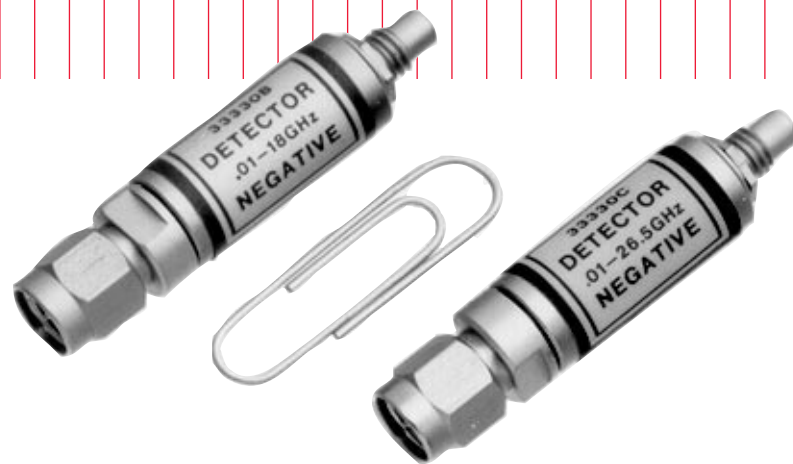

General Information

The Keysight Technologies, Inc. 33330B/C Series of broadband coaxial detectors are specifically designed for use in microwave instrumentation and systems applications such as the detecting element in leveling loops, power monitoring, and as wideband video detectors.

These detectors utilize a Low Barrier Schottky (LBS) diode that requires no bias, has exceptional broadband flatness and low SWR, and is environmentally rugged. For measurement accessory applications, Keysight offers similar RF performance with a variety of input and output connectors in the Model 423B, 8470B, and 8472B Series.

The Low Barrier Schottky diode detector

The 33330B/C detectors consist of a Low Barrier Schottky (LBS) diode and a miniature thin film circuit that matches the diode to a 50-ohm transmission line. The diode is a specially fabricated Schottky diode using metalization designed to achieve low origin resistance, thus eliminating the need for bias. In addition to superior RF characteristics, the LBS detector offers significant advantages over other types of detectors. For example, a typical Schottky requires bias for proper operation; a tunnel diode detector has a limited power range because of its negative resistance region; and the point contact diode, because of its fragile construction, is unsuitable for many field applications.

Frequency Range

- Broadband (0.01 to 26.5 GHz)
- Excellent flatness (± 0.6 dB to 18 GHz)
- Low SWR (< 1.5 to 18 GHz)
- Environmentally rugged (MIL-STD 883 tests)
- Field replaceable diode modules
- APC 3.5-mm connector (reliable, SMA compatible)
- Low Barrier Schottky diode (no bias required)

Since only metallurgical bonds are used with the diode, the detectors are extremely rugged. As noted on page 4, the detectors have undergone extensive environmental testing to MIL-STD 883 procedures, an important factor in military systems applications. The detector can also withstand high RF power levels for short durations without burnout, important for power monitoring applications. For example, it can typically withstand 1 watt CW for a minute without permanent damage.

The equivalent circuit and pulse response equations for the 33330B/C detectors are shown in Figures 1 and 2, and extensive data on the performance of the detectors is given on page 3. Using this information, the user can select a load to extend the square law region to higher power levels or to minimize the output variation over a given temperature range.

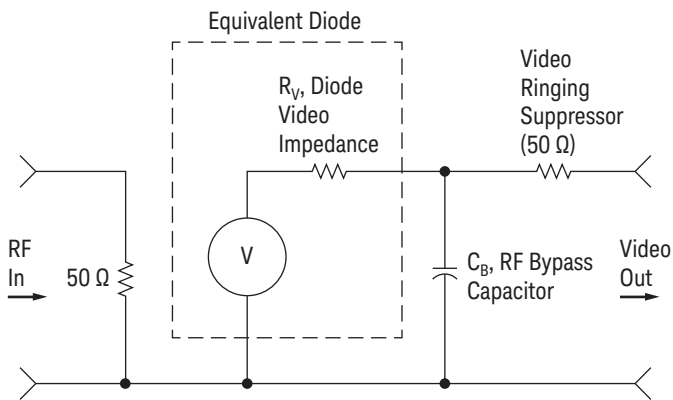

Typical Values:

$$R_V \text{ (Diode Video Impedance)} \cong 1.3 \text{ k}\Omega *$$

$$C_B \text{ (RF Bypass Capacitor)} \cong 30 \text{ pF nominal}$$

$$T_R \text{ (10 to 90% Risetime)} \cong 2.2 \frac{(R_{LOAD})(R_V)}{R_{LOAD} + R_V} (C_B + C_{LOAD})$$

* @ 25 °C and $P_{IN} < -20 \text{ dBm}$ (see Figure 7)

Figure 1. Equivalent circuit for the Keysight 33330B/C detectors with typical parameter values

Excellent broadband flatness

The thin film input matching circuit was optimized for flat frequency response and low SWR, which yields improved performance in leveling loops and power monitoring applications. Use of thin film fabrication techniques for the circuit and diode results in excellent unit-to-unit repeatability of performance, and thus matched pairs will track within a few tenths of a dB over the entire frequency range (see Figure 2). This feature is especially important in the 20 to 26.5 GHz frequency range where diode capacitance causes the sensitivity to decrease by 3.3 dB, yet this “roll off” characteristic is very repeatable and matched pairs will track within $\pm 0.5 \text{ dB}$.

Low SWR

The miniature thin film circuit used provides an excellent 50-ohm match to the transmission line, which

minimizes reflections that cause frequency response ripple and power measurement inaccuracies. Such errors can be significant. For example, using a detector with an SWR of 2.5:1 in an application with a 2:1 source match can result in more than a $\pm 1.3 \text{ dB}$ ripple. For the same source match of 2:1, a typical 33330B detector with SWR less than 1.25 would have less than $\pm 0.4 \text{ dB}$ ripple.

APC 3.5-mm connector improves performance and extends frequency range

The Keysight 33330B/C detectors use the APC-3.5 connector, which is compatible with the industry standard SMA but is more rugged and offers improved repeatability over hundreds of connections. Use of this connector extends the frequency range of the 33330C to 26.5 GHz.

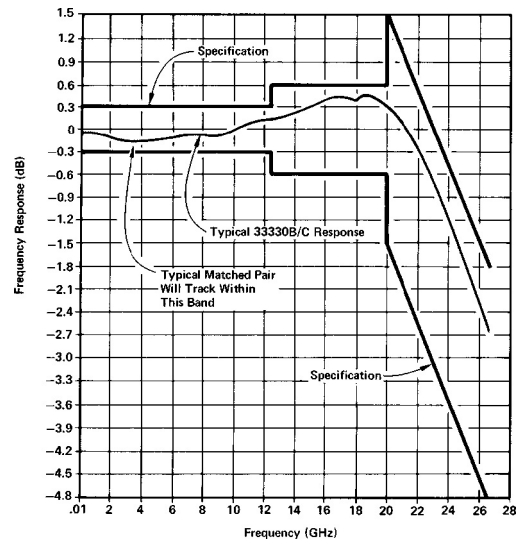

Figure 2. Typical frequency response of the Keysight 33330B/C detectors

Detector Performance Characteristics

Typical transfer characteristics

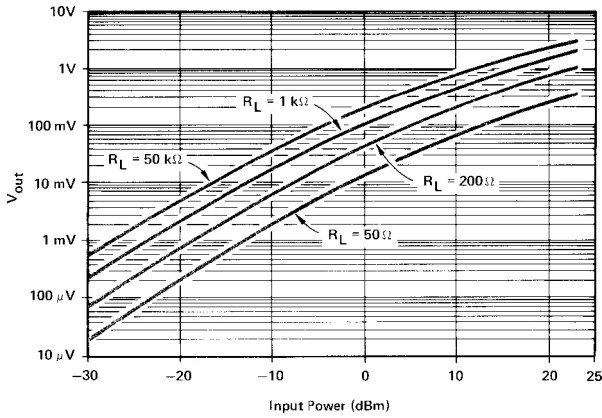

Figure 3. Typical transfer characteristics ($T_a = 25^\circ\text{C}$)

Typical temperature characteristics

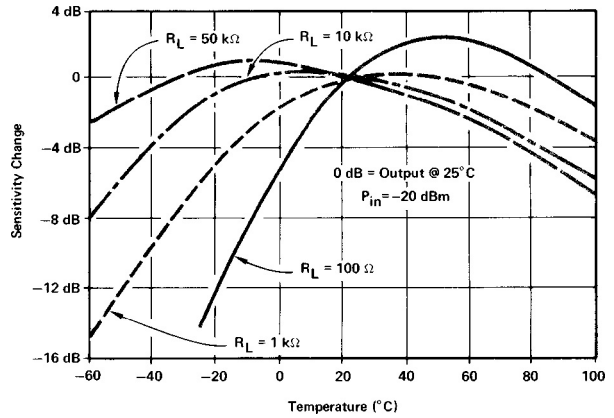

Figure 6. Typical output response with temperature ($P_{in} < -20 \text{ dBm}$)

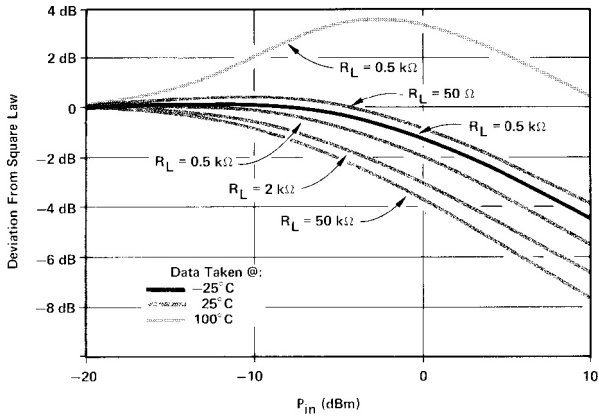

Figure 4. Typical square law deviation

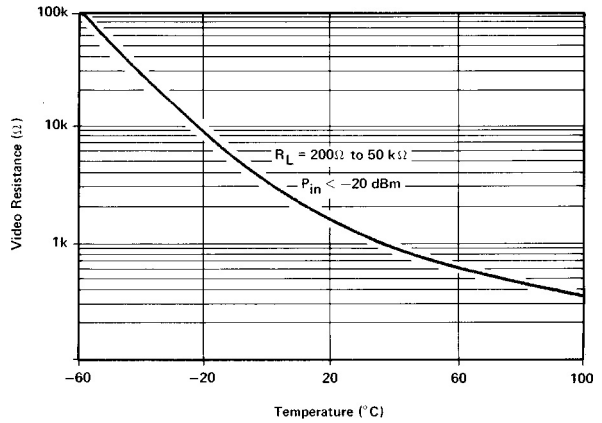

Figure 7. Typical video impedance variation with temperature

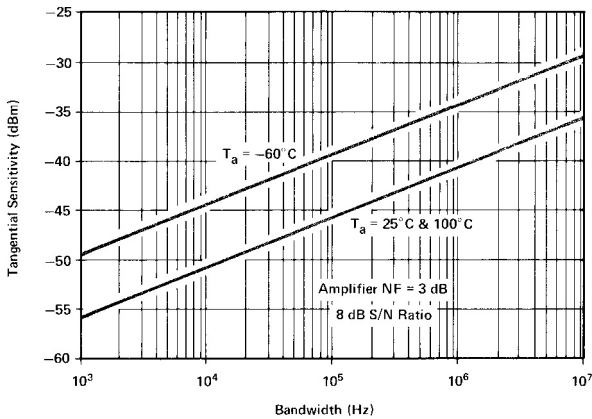

Figure 5. Typical tangential sensitivity

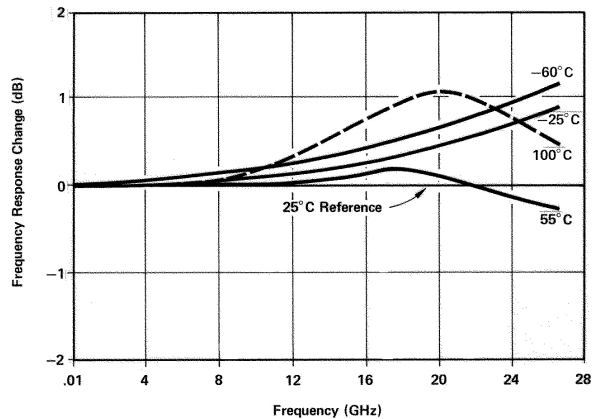

Figure 8. Typical frequency response variation with temperature

Specifications¹

	33330B	33330C
Frequency range ²	0.01 to 18 GHz	0.01 to 26.5 GHz
Frequency response		
Octave band flatness	±0.2 dB over any octave to 8 GHz	±0.2 dB over any octave to 8 GHz
Broadband flatness	0.01 to 12.4 GHz: ±0.3 dB 0.01 to 18 GHz: ±0.6 dB	0.01 to 12.4 GHz: ±0.3 dB 0.01 to 20 GHz: ±0.6 dB 20 to 26.5 GHz: ±1.5 dB from a -3.3 dB linear slope
SWR	0.01 to 4 GHz: 1.2 0.01 to 18 GHz: 1.5	0.01 to 4 GHz: 1.2 4 to 18 GHz: 1.5 18 to 26.5 GHz: 2.2
Low level sensitivity	> 0.5 mV/μW	0.01 to 18 GHz: > 0.5 mV/μW 18 to 26.5 GHz: > 0.18 mV/μW
Maximum operating input	200 mW	200 mW
Typical short-term maximum input (less than 1 minute)	1 watt (typical)	1 watt (typical)
Noise (μV peak to peak with CW power applied to produce 100 mV output, 400 kHz BW)	< 50 μV	< 50 μV
Output polarity		Negative (default Option 301), Positive (Option 003)
Matched response ³	0.01 to 12.4 GHz: ±0.2 dB 0.01 to 18 GHz: ±0.3 dB	0.01 to 12.4 GHz: ±0.2 dB 0.01 to 18 GHz: ±0.3 dB 0.01 to 26.5 GHz: ±0.5 dB
Option 003		
Environmental capabilities ⁴		
Operating temperatures ⁵		-65 to 100 °C
Temperature cycling		MIL-STD 883. Method 1010.1: (-65 to ±100 °C)
Vibration		MIL-STD 883. Method 2007 0.6" D.A. (20 to 80 Hz) and 20 G (80 to 2000 Hz)
Shock		MIL-STD 883. Method 2002.1 (500 G. 0.5 ms)
Acceleration		MIL-STD 883. Method 2001 (5000 G)
Altitude ⁶		MIL-STD 883. Method 1001: (50,000 ft. 15,240 m)
Salt atmosphere ⁷		MIL-STD 883. Method 1009.1: (48 hr. 5% solution)
Moisture resistance		
With epoxy coating ⁷		MIL-STD 883. Method 1004.1: (25 to 65 °C, 95% RH)
Without coating		25 to 40 °C, 95% RH

1. Measured at 25 °C and < -20 dBm unless otherwise specified.
2. Below 1 GHz RF may leak through the video connector. If objectionable, this may be eliminated with a low pass filter.
3. Option 001 must be ordered for each matched pair. Default option is Option 101, no matched pair.
4. Additional information available upon request.
5. Typical variations with temperature are shown on page 3.
6. Tested only to 50,000 ft (15,240 m), capable of much higher performance.
7. Use of an epoxy coating is required for meeting these requirements. Contact your Keysight Components Field Engineer for details.

Field replaceable diode modules

In the event of diode burnout, the detector module can be replaced in the field. Since the replacement module includes the tested and sealed assembly of diode and thin-film matching circuit, the user is assured of performance to specifications. This offers an advantage over detector designs where only the diode is replaced and not tested in its final assembly.

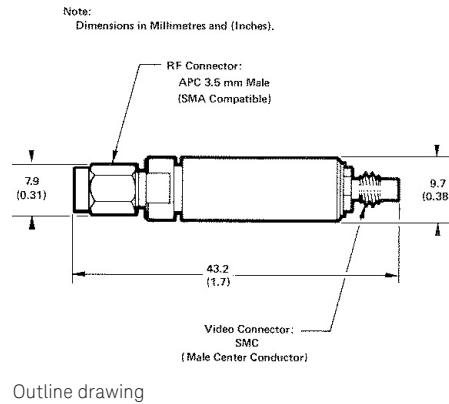

Model number	Description	Replacement module part number
33330B Option 301	Negative polarity	33330-80003
33330B Option 001	Matched pair (negative)	33330-80004
33330B Option 003	Positive polarity	33330-80005
33330C Option 301	Negative polarity	33330-80006
33330C Option 001	Matched pair (negative)	33330-80007
33330C Option 003	Positive polarity	33330-80008

Mechanical information	
RF connector	APC-3.5 male (SMA compatible)
Output connector	SMC (male center conductor)
Net weight	14 g (0.5 oz)

Evolving Since 1939

Our unique combination of hardware, software, services, and people can help you reach your next breakthrough. We are unlocking the future of technology.

From Hewlett-Packard to Agilent to Keysight.

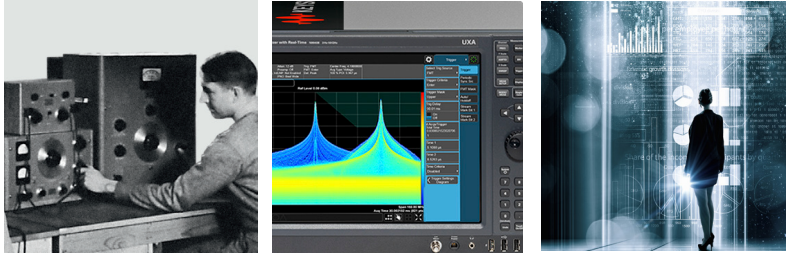

For more information on Keysight Technologies' products, applications or services, please contact your local Keysight office. The complete list is available at:

www.keysight.com/find/contactus

Americas

Canada	(877) 894 4414
Brazil	55 11 3351 7010
Mexico	001 800 254 2440
United States	(800) 829 4444

Asia Pacific

Australia	1 800 629 485
China	800 810 0189
Hong Kong	800 938 693
India	1 800 11 2626
Japan	0120 (421) 345
Korea	080 769 0800
Malaysia	1 800 888 848
Singapore	1 800 375 8100
Taiwan	0800 047 866
Other AP Countries	(65) 6375 8100

Europe & Middle East

Austria	0800 001122
Belgium	0800 58580
Finland	0800 523252
France	0805 980333
Germany	0800 6270999
Ireland	1800 832700
Israel	1 809 343051
Italy	800 599100
Luxembourg	+32 800 58580
Netherlands	0800 0233200
Russia	8800 5009286
Spain	800 000154
Sweden	0200 882255
Switzerland	0800 805353
	Opt. 1 (DE)
	Opt. 2 (FR)
	Opt. 3 (IT)
United Kingdom	0800 0260637

For other unlisted countries:

www.keysight.com/find/contactus
(BP-9-7-17)



www.keysight.com/go/quality
Keysight Technologies, Inc.
DEKRA Certified ISO 9001:2015
Quality Management System

myKeysight

myKeysight

www.keysight.com/find/mykeysight

A personalized view into the information most relevant to you.

http://www.keysight.com/find/emt_product_registration

Register your products to get up-to-date product information and find warranty information.



Keysight Services

www.keysight.com/find/service

Keysight Services can help from acquisition to renewal across your instrument's lifecycle. Our comprehensive service offerings—one-stop calibration, repair, asset management, technology refresh, consulting, training and more—helps you improve product quality and lower costs.

Keysight Assurance Plans

www.keysight.com/find/AssurancePlans

Up to ten years of protection and no budgetary surprises to ensure your instruments are operating to specification, so you can rely on accurate measurements.

Keysight Channel Partners

www.keysight.com/find/channelpartners

Get the best of both worlds: Keysight's measurement expertise and product breadth, combined with channel partner convenience.

www.keysight.com/find/mta



This information is subject to change without notice.

© Keysight Technologies, 2017
Published in USA, December 2, 2017
5952-8164E
www.keysight.com